

# Model: WB 5000KG

1KG=2.205LB 1INCH=25.40MM

Model		WB	
Capacity	Q(kg)	5000	5000
Lowered fork height	$h_{13}$ (mm)	88	78
Steering wheel	mm	$\phi$ 200	$\phi$ 180
Fork wheel single	mm	~	~
Fork wheel tandem	mm	$\phi$ 85x80	$\phi$ 75x80
Max. lift height	$h_4$ (mm)	205	195
Total height	$h_{14}$ (mm)	1253	1243
Overall length	$l$ (mm)	1544/1614	1544/1614
Fork length	$l$ (mm)	1150/1220	1150/1220
Width overall forks	$b$ (mm)	550/685	550/685
Ground clearance, centre of wheelbase	$m$ (mm)	28	18
Aisle width for pallets 1000x1200 crossways	$A_4$ (mm)	1744/1814	1744/1814
Aisle width for pallets 800x1200 lengthways	$A_4$ (mm)	1794/1814	1794/1814
Turning radius	$W$ (mm)	1300/1370	1300/1370
Service weight	kg	103-110	103-110

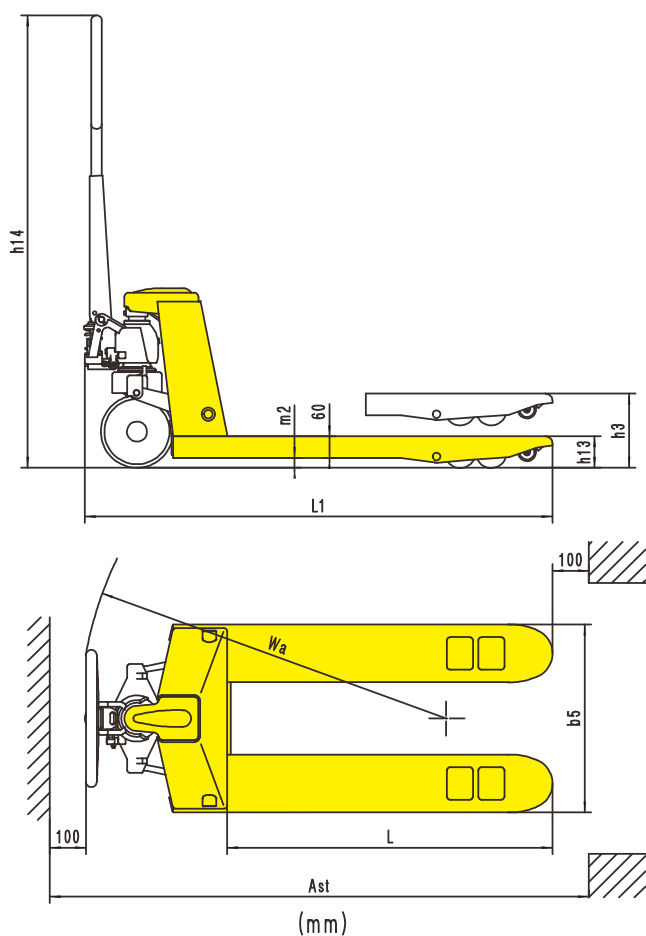
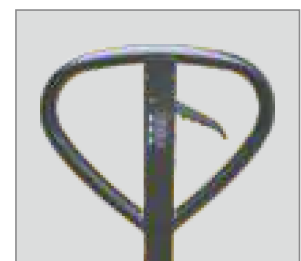
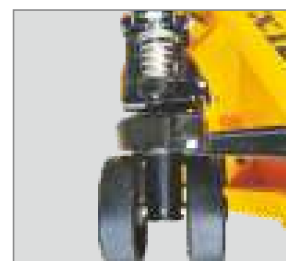

## Heavy duty type pallet truck

- High reliability and long service life of 5 years.
- Double lifting speed when loads under 600kg, which turns back to regular speed when above it.
- Impact free lifting ensures safety of cargo loading.
- The lifting system is equipped with overloading protection valve to ensure the safe operation.
- The utilized structural design guarantees the convenience of assembling and disassembling.
- Light-weight fork frame, made from high rigidity steel plate.
- Compact appearance, complete rocker arm, ensure the whole truck evenly pressed.
- There is a finger hole in the connection of handle and pump, easy to assemble.